

Fotografie di gamma



Sovrastruttura refrigerata per pizzeria completa di vetrina in cristallo e di bacinelle



Banco preparazione pizza completo di:

- Tavolo frigorifero a due sportelli con gruppo incorporato
- Cassettiera neutra a tre cassetti più cassettone
- Piano in marmo con alzatine laterali
- Sovrastruttura refrigerata con vetrina

Banco preparazione pizza completo di:

- Tavolo frigorifero a due sportelli con gruppo incorporato
- Cassettiera neutra a sei cassetti
- Piano in marmo con alzatine laterali
- Sovrastruttura refrigerata con coperchio Inox



Banchi pizza composti

Tavolo frigorifero con vano per bacinelle da mm. 400x600
Sovrastruttura con vetrina in cristallo e vasca per bacinelle GN1/2
Cassettiera neutra con nr° 6 cassetti completi di bacinelle 400x600

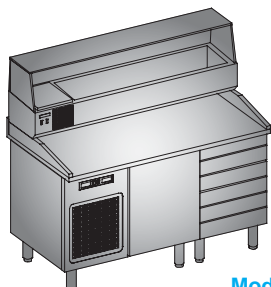

Mod. LA-12CRC

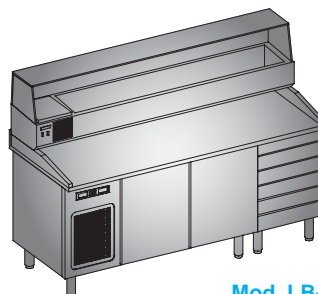

Mod. LB-12CRC

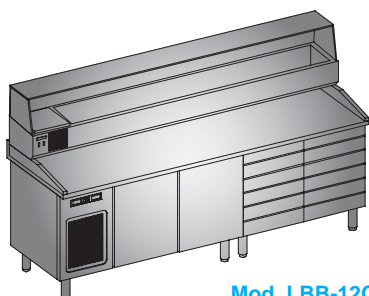

Mod. LBB-12CRC

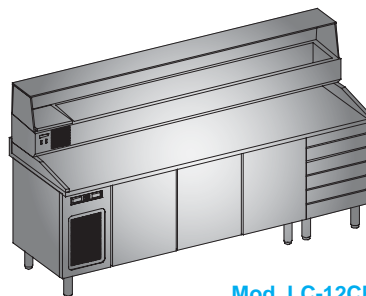

Mod. LC-12CRC

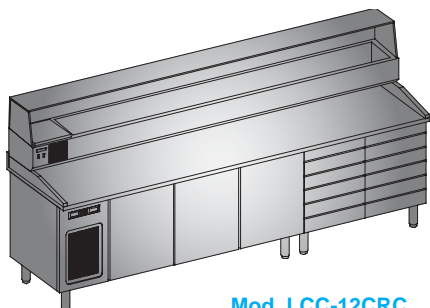

Mod. LCC-12CRC

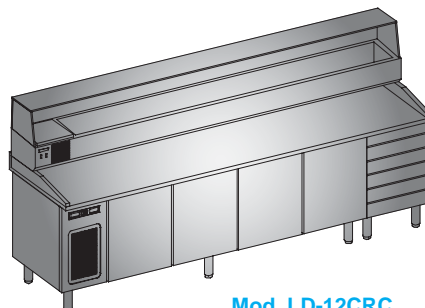

Mod. LD-12CRC

	Mod.	LxPxH mm	Ante refrigerate	V - Hz	°C	Composizione
<input type="checkbox"/>	LA-12CRC	1500x800x1450H	1	230/1+T-50	0 ÷ +10	P1CGI+M15-8P3A+S15S2+V2-15+LBB-7P
<input type="checkbox"/>	LB-12CRC	2000x800x1450H	2	230/1+T-50	0 ÷ +10	P2CGI +M20-8P3A+S20S2+V2-20+LBB-7P
<input type="checkbox"/>	LBB-12CRC	2500x800x1450H	2	230/1+T-50	0 ÷ +10	P2CGI +M25-8P3A+S25S2+V2-25+LBB-7P-2
<input type="checkbox"/>	LC-12CRC	2500x800x1450H	3	230/1+T-50	0 ÷ +10	P3CGI +M25-8P3A+S25S2+V2-25+LBB-7P
<input type="checkbox"/>	LCC-12CRC	3000x800x1450H	3	230/1+T-50	0 ÷ +10	P3CGI +M30-8P3A+S30S2+V2-30 +LBB-7P-2
<input type="checkbox"/>	LD-12CRC	3000x800x1450H	4	230/1+T-50	0 ÷ +10	P4CGI +M30-8P3A+S30S2+V2-30+LBB-7P

Dotazioni basi refrigerate : Nr. 1 coppia guida e nr. 1 griglia per ogni singola anta.

N.B.: Prezzo escluso bacinelle per sovrastrutture

Banchi pizza composti

Tavolo frigorifero con vano per bacinelle da mm. 400x600
Sovrastruttura con coperchio in acciaio Inox Aisi304 e vasca per bacinelle GN1/2
Cassettiera neutra con nr° 3 cassetti e nr° 1 cassettone completo di bacinelle 400x600

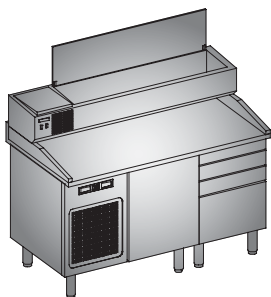

Mod. LA-12PO

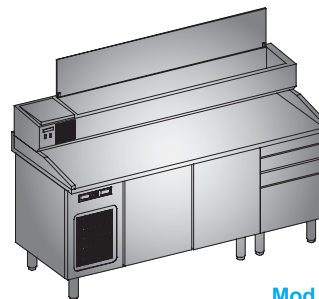

Mod. LB-12PO

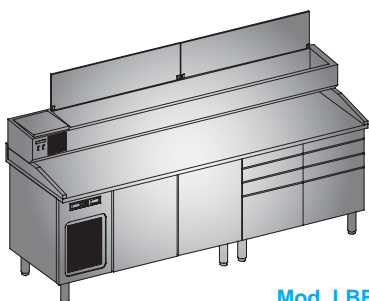

Mod. LBB-12PO

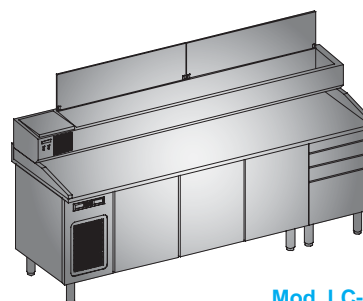

Mod. LC-12PO

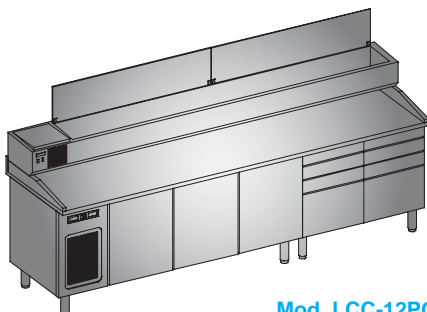

Mod. LCC-12PO

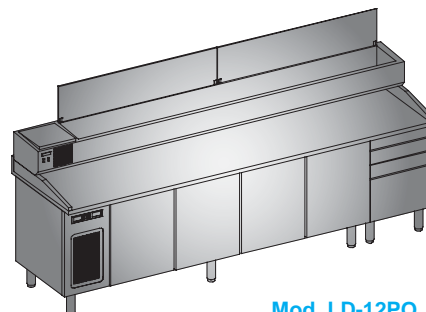

Mod. LD-12PO

Mod.	LxPxH mm	Ante refrigerate	V - Hz	°C	Composizione
<input type="checkbox"/> LA-12PO	1500x800x1450H	1	230/1+T-50	0 ÷ +10	P1CGI+M15-8P3A+S15S2+COP2-15I+LBA-7P
<input type="checkbox"/> LB-12PO	2000x800x1450H	2	230/1+T-50	0 ÷ +10	P2CGI+M20-8P3A+S20S2+COP2-20I+LBA-7P
<input type="checkbox"/> LBB-12PO	2500x800x1450H	2	230/1+T-50	0 ÷ +10	P2CGI+M25-8P3A+S25S2+COP2-25I+LBA-7P-2
<input type="checkbox"/> LC-12PO	2500x800x1450H	3	230/1+T-50	0 ÷ +10	P3CGI+M25-8P3A+S25S2+COP2-25I+LBA-7P
<input type="checkbox"/> LCC-12PO	3000x800x1450H	3	230/1+T-50	0 ÷ +10	P3CGI+M30-8P3A+S30S2+COP2-30I+LBA-7P-2
<input type="checkbox"/> LD-12PO	3000x800x1450H	4	230/1+T-50	0 ÷ +10	P4CGI+M30-8P3A+S30S2+COP2-30I+LBA-7P

Dotazioni basi refrigerate : Nr. 1 coppia guida e nr. 1 griglia per ogni singola anta.

N.B.: Prezzo escluso bacinelle per sovrastrutture

Banchi pizza composti

Tavolo frigorifero con vano per bacinelle da mm. 400x600
Sovrastruttura con coperchio in acciaio Inox Aisi304 e vasca per bacinelle GN1/2
Cassettiera neutra con nr° 6 cassetti completi di bacinelle 400x600

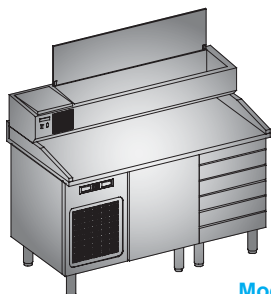

Mod. LA-12POC

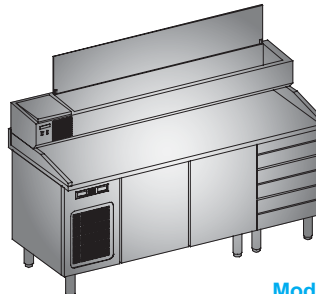

Mod. LB-12POC

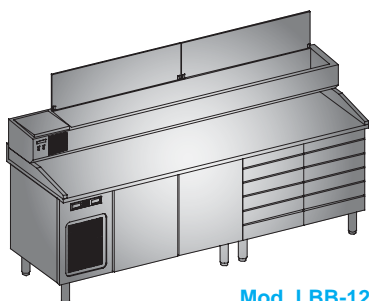

Mod. LBB-12POC

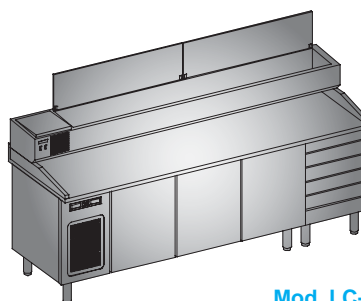

Mod. LC-12POC

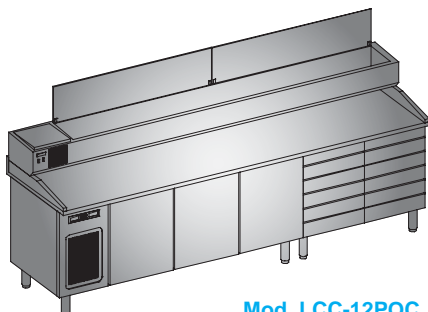

Mod. LCC-12POC

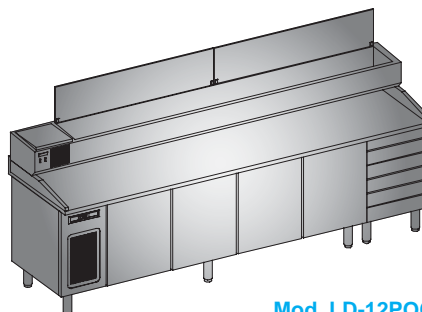

Mod. LD-12POC

Mod.	LxPxH mm	Ante refrigerate	V - Hz	°C	Composizione
<input type="checkbox"/> LA-12POC	1500x800x1450H	1	230/1+T-50	0 ÷ +10	P1CGI+M15-8P3A+S15S2+COP2-15I+LBB-7P
<input type="checkbox"/> LB-12POC	2000x800x1450H	2	230/1+T-50	0 ÷ +10	P2CGI+M20-8P3A+S20S2+COP2-20I+LBB-7P
<input type="checkbox"/> LBB-12POC	2500x800x1450H	2	230/1+T-50	0 ÷ +10	P2CGI+M25-8P3A+S25S2+COP2-25I+LBB-7P-2
<input type="checkbox"/> LC-12POC	2500x800x1450H	3	230/1+T-50	0 ÷ +10	P3CGI+M25-8P3A+S25S2+COP2-25I+LBB-7P
<input type="checkbox"/> LCC-12POC	3000x800x1450H	3	230/1+T-50	0 ÷ +10	P3CGI+M30-8P3A+S30S2+COP2-30I+LBB-7P-2
<input type="checkbox"/> LD-12POC	3000x800x1450H	4	230/1+T-50	0 ÷ +10	P4CGI+M30-8P3A+S30S2+COP2-30I+LBB-7P

Dotazioni basi refrigerate : Nr. 1 coppia guida e nr. 1 griglia per ogni singola anta.

N.B.: Prezzo escluso bacinelle per sovrastrutture

Banchi pizza composti

Tavolo frigorifero con vano per bacinelle da mm. 400x600

Sovrastruttura con vetrina in cristallo e vasca per bacinelle GN1/1

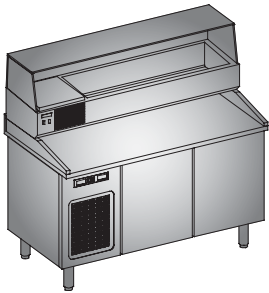

Mod. LBF-11CR

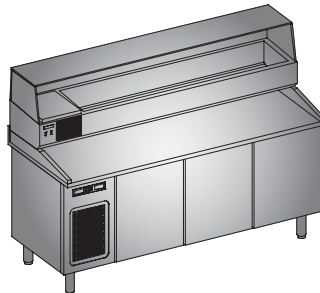

Mod. LCF-11CR

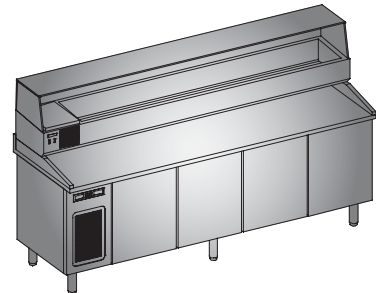

Mod. LDF-11CR

Mod.	LxPxH mm	Ante refrigerate	V - Hz	°C	Composizione
<input type="checkbox"/> LBF-11CR	1500x800x1450H	2	230/1+T-50	0 ÷ +10	P2CGI+M15-8P3A+S15S1+V1-15
<input type="checkbox"/> LCF-11CR	2000x800x1450H	3	230/1+T-50	0 ÷ +10	P3CGI+M20-8P3A+S20S1+V1-20
<input type="checkbox"/> LDF-11CR	2500x800x1450H	4	230/1+T-50	0 ÷ +10	P4CGI+M25-8P3A+S25S1+V1-25

Banchi pizza composti

Tavoli frigoriferi con vano per griglia mm. 400x600

Sovrastruttura con vetrina in cristallo e vasca per bacinelle GN1/2



Mod. LBF-12CR

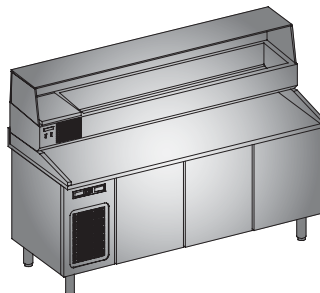

Mod. LCF-12CR

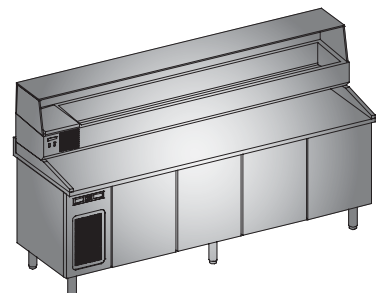

Mod. LDF-12CR

Mod.	LxPxH mm	Ante refrigerate	V - Hz	°C	Composizione
<input type="checkbox"/> LBF-12CR	1500x800x1450H	2	230/1+T-50	0 ÷ +10	P2CGI+M15-8P3A+S15S2+V2-15
<input type="checkbox"/> LCF-12CR	2000x800x1450H	3	230/1+T-50	0 ÷ +10	P3CGI+M20-8P3A+S20S2+V2-20
<input type="checkbox"/> LDF-12CR	2500x800x1450H	4	230/1+T-50	0 ÷ +10	P4CGI+M25-8P3A+S25S2+V2-25

Dotazioni basi refrigerate : Nr. 1 coppia guida e nr. 1 griglia per ogni singola anta.

N.B.: Prezzo escluso bacinelle per sovrastrutture

Banchi pizza composti

Tavolo frigorifero con vano per bacinelle da mm. 400x600

Sovrastruttura con vetrina in cristallo e vasca per bacinelle GN1/1

Cassettiera neutra con nr° 3 cassetti e nr° 1 cassettone completi di bacinelle 400x600

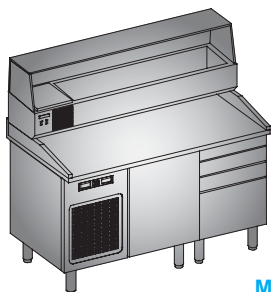

Mod. LA-11CR

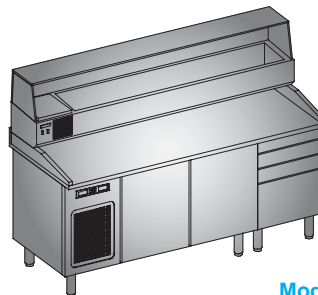

Mod. LB-11CR

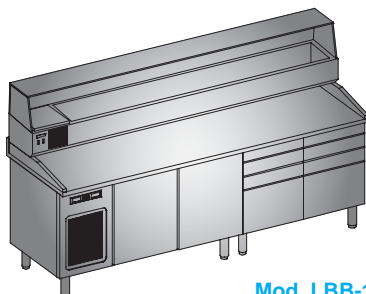

Mod. LBB-11CR

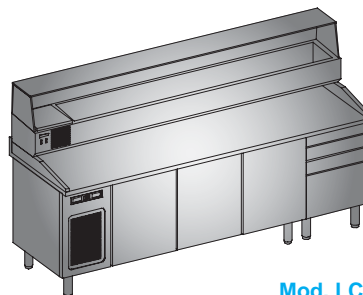

Mod. LC-11CR

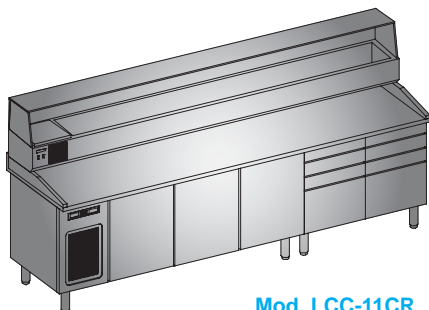

Mod. LCC-11CR

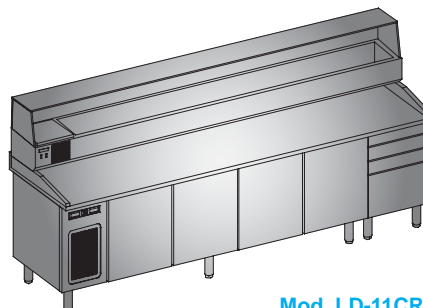

Mod. LD-11CR

Mod.	LxPxH mm	Ante refrigerate	V - Hz	°C	Composizione
<input type="checkbox"/> LA-11CR	1500x800x1450H	1	230/1+T-50	0 ÷ +10	P1CGI+M15-8P3A+S15S1+V1-15+LBA-7P
<input type="checkbox"/> LB-11CR	2000x800x1450H	2	230/1+T-50	0 ÷ +10	P2CGI+M20-8P3A+S20S1+V1-20+LBA-7P
<input type="checkbox"/> LBB-11CR	2500x800x1450H	2	230/1+T-50	0 ÷ +10	P2CGI+M25-8P3A+S25S1+V1-25+LBA-7P-2
<input type="checkbox"/> LC-11CR	2500x800x1450H	3	230/1+T-50	0 ÷ +10	P3CGI+M25-8P3A+S25S1+V1-25+LBA-7P
<input type="checkbox"/> LCC-11CR	3000x800x1450H	3	230/1+T-50	0 ÷ +10	P3CGI+M30-8P3A+S30S1+V1-30+LBA-7P-2
<input type="checkbox"/> LD-11CR	3000x800x1450H	4	230/1+T-50	0 ÷ +10	P4CGI+M30-8P3A+S30S1+V1-30+LBA-7P

Dotazioni basi refrigerate : Nr. 1 coppia guida e nr. 1 griglia per ogni singola anta.

N.B.: Prezzo escluso bacinelle per sovrastrutture

Banchi pizza composti

Tavolo frigorifero con vano per bacinelle da mm. 400x600
Sovrastruttura con vetrina in cristallo e vasca per bacinelle GN1/1
Cassettiera neutra con nr° 6 cassetti completi di bacinelle 400x600

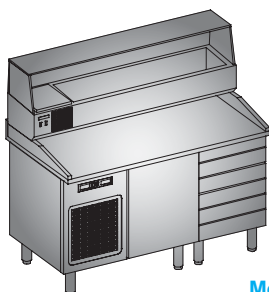

Mod. LA-11CRC

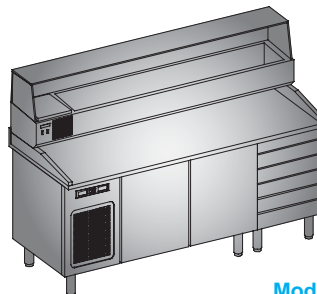

Mod. LB-11CRC

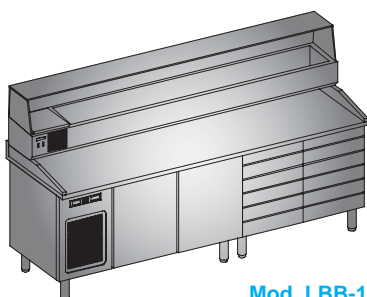

Mod. LBB-11CRC

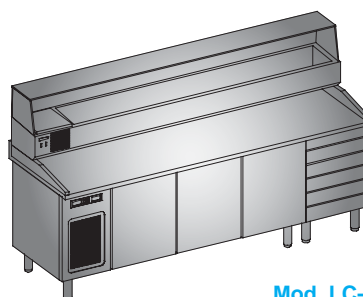

Mod. LC-11CRC

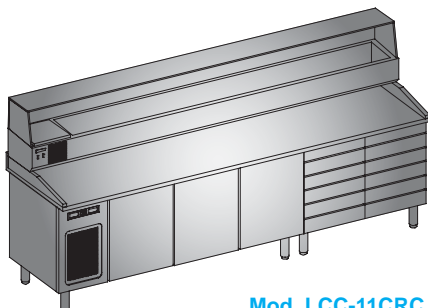

Mod. LCC-11CRC

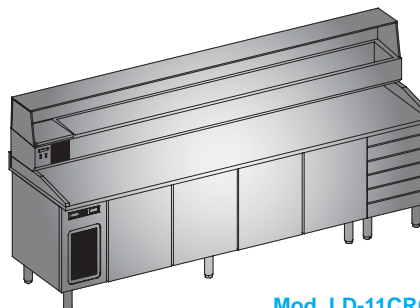

Mod. LD-11CRC

Mod.	LxPxH mm	Ante refrigerate	V - Hz	°C	Composizione
<input type="checkbox"/> LA-11CRC	1500x800x1450H	1	230/1+T-50	0 ÷ +10	P1CGI+M15-8P3A+S15S1+V1-15+LBB-7P
<input type="checkbox"/> LB-11CRC	2000x800x1450H	2	230/1+T-50	0 ÷ +10	P2CGI+M20-8P3A+S20S1+V1-20+LBB-7P
<input type="checkbox"/> LBB-11CRC	2500x800x1450H	2	230/1+T-50	0 ÷ +10	P2CGI+M25-8P3A+S25S1+V1-25+LBB-7P-2
<input type="checkbox"/> LC-11CRC	2500x800x1450H	3	230/1+T-50	0 ÷ +10	P3CGI+M25-8P3A+S25S1+V1-25+LBB-7P
<input type="checkbox"/> LCC-11CRC	3000x800x1450H	3	230/1+T-50	0 ÷ +10	P3CGI+M30-8P3A+S30S1+V1-30+LBB-7P-2
<input type="checkbox"/> LD-11CRC	3000x800x1450H	4	230/1+T-50	0 ÷ +10	P4CGI+M30-8P3A+S30S1+V1-30+LBB-7P

Dotazioni basi refrigerate : Nr. 1 coppia guida e nr. 1 griglia per ogni singola anta.

N.B.: Prezzo escluso bacinelle per sovrastrutture

Banchi pizza composti

Tavolo frigorifero con vano per bacinelle da mm. 400x600

Sovrastruttura con coperchio in acciaio Inox Aisi304 e vasca per bacinelle GN1/1

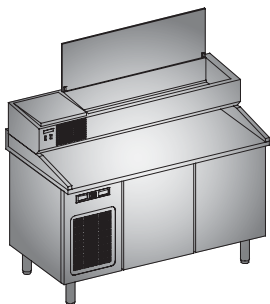

Mod. LBF-11PO

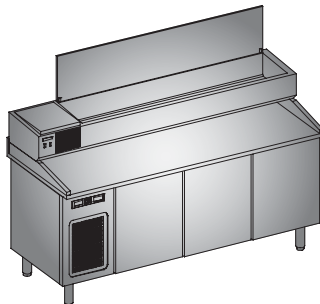

Mod. LCF-11PO

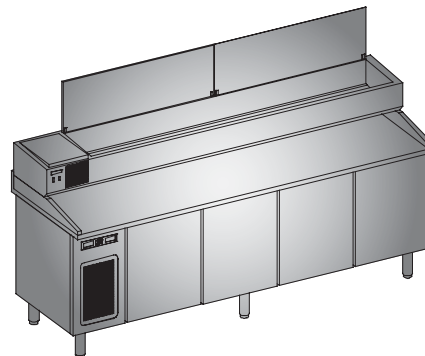

Mod. LDF-11PO

Mod.	LxPxH mm	Ante refrigerate	V - Hz	°C	Composizione
<input type="checkbox"/> LBF-11PO	1500x800x1450H	2	230/1+T-50	0 ÷ +10	P2CGI+M15-8P3A+S15S1+COP1-15I
<input type="checkbox"/> LCF-11PO	2000x800x1450H	3	230/1+T-50	0 ÷ +10	P3CGI+M20-8P3A+S20S1+COP1-20I
<input type="checkbox"/> LDF-11PO	2500x800x1450H	4	230/1+T-50	0 ÷ +10	P4CGI+M25-8P3A+S25S1+COP1-25I

Banchi pizza composti

Tavoli frigoriferi con vano per griglia mm. 400x600

Sovrastruttura con coperchio in acciaio Inox Aisi304 e vasca per bacinelle GN1/2

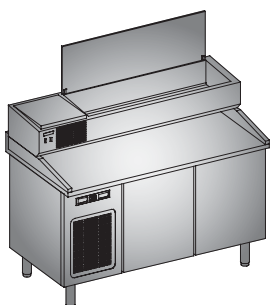

Mod. LBF-12PO

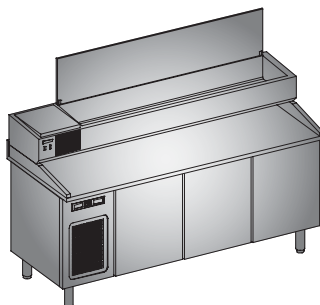

Mod. LCF-12PO

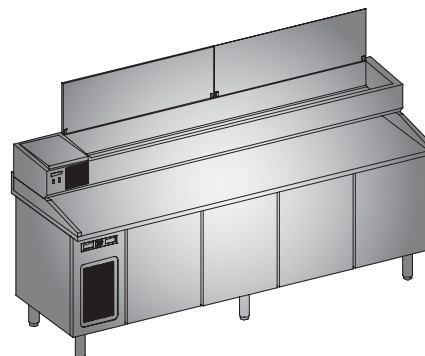

Mod. LDF-12PO

Mod.	LxPxH mm	Ante refrigerate	V - Hz	°C	Composizione
<input type="checkbox"/> LBF-12PO	1500x800x1450H	2	230/1+T-50	0 ÷ +10	P2CGI+M15-8P3A+S15S2+COP2-15I
<input type="checkbox"/> LCF-12PO	2000x800x1450H	3	230/1+T-50	0 ÷ +10	P3CGI+M20-8P3A+S20S2+COP2-20I
<input type="checkbox"/> LDF-12PO	2500x800x1450H	4	230/1+T-50	0 ÷ +10	P4CGI+M25-8P3A+S25S2+COP2-25I

Dotazioni basi refrigerate : Nr. 1 coppia guida e nr. 1 griglia per ogni singola anta.

N.B.: Prezzo escluso bacinelle per sovrastrutture

Banchi pizza composti

Tavolo frigorifero con vano per bacinelle da mm. 400x600
Sovrastruttura con coperchio in acciaio Inox Aisi304 e vasca per bacinelle GN1/1
Cassettiera neutra con nr° 3 cassetti e nr° 1 cassettone completi di bacinelle 400x600

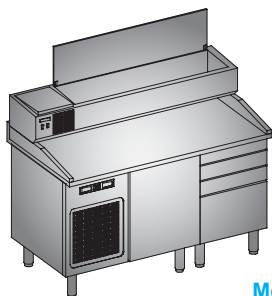

Mod. LA-11PO

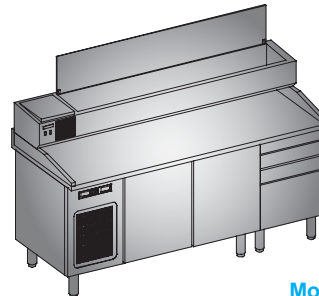

Mod. LB-11PO

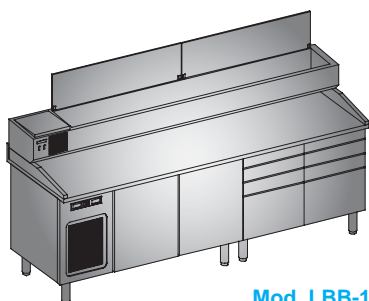

Mod. LBB-11PO

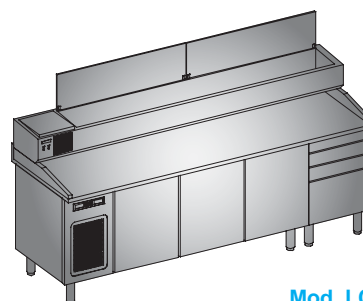

Mod. LC-11PO

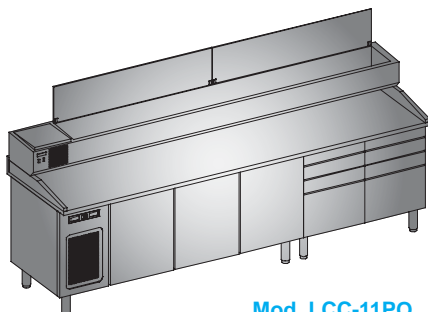

Mod. LCC-11PO

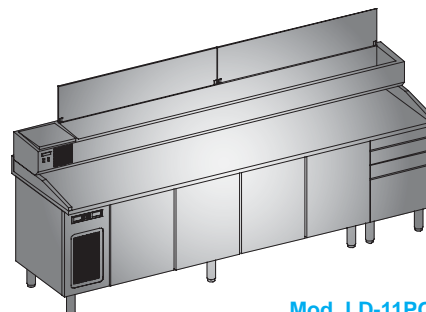

Mod. LD-11PO

Mod.	LxPxH mm	Ante refrigerate	V - Hz	°C	Composizione
<input type="checkbox"/> LA-11PO	1500x800x1450H	1	230/1+T-50	0 ÷ +10	P1CGI+M15-8P3A+S15S1+COP1-15I+LBA-7P
<input type="checkbox"/> LB-11PO	2000x800x1450H	2	230/1+T-50	0 ÷ +10	P2CGI+M20-8P3A+S20S1+COP1-20I+LBA-7P
<input type="checkbox"/> LBB-11PO	2500x800x1450H	2	230/1+T-50	0 ÷ +10	P2CGI+M25-8P3A+S25S1+COP1-25I+LBA-7P-2
<input type="checkbox"/> LC-11PO	2500x800x1450H	3	230/1+T-50	0 ÷ +10	P3CGI+M25-8P3A+S25S1+COP1-25I+LBA-7P
<input type="checkbox"/> LCC-11PO	3000x800x1450H	3	230/1+T-50	0 ÷ +10	P3CGI+M30-8P3A+S30S1+COP1-30I+LBA-7P-2
<input type="checkbox"/> LD-11PO	3000x800x1450H	4	230/1+T-50	0 ÷ +10	P4CGI+M30-8P3A+S30S1+COP1-30I+LBA-7P

Dotazioni basi refrigerate : Nr. 1 coppia guida e nr. 1 griglia per ogni singola anta.

N.B.: Prezzo escluso bacinelle per sovrastrutture

Banchi pizza composti

Tavolo frigorifero con vano per bacinelle da mm. 400x600
Sovrastruttura con coperchio in acciaio Inox Aisi304 e vasca per bacinelle GN1/1
Cassettiera neutra con nr° 6 cassetti completi di bacinelle 400x600

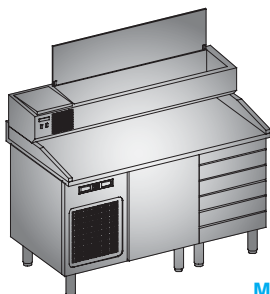

Mod. LA-11POC

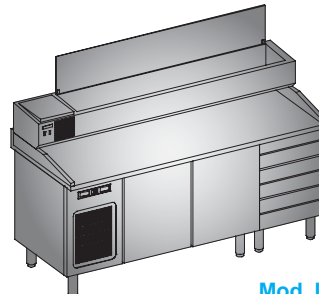

Mod. LB-11POC

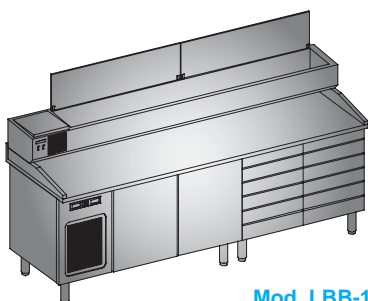

Mod. LBB-11POC

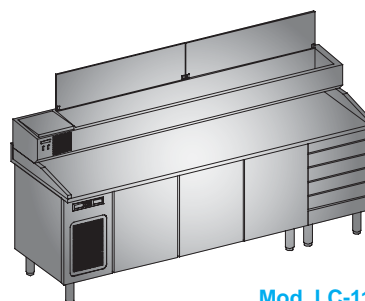

Mod. LC-11POC

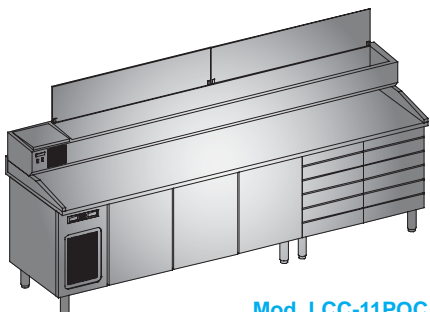

Mod. LCC-11POC

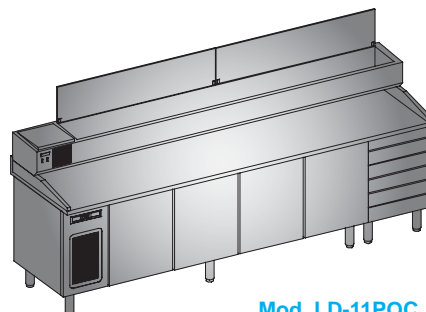

Mod. LD-11POC

Mod.	LxPxH mm	Ante refrigerate	V - Hz	°C	Composizione
<input type="checkbox"/> LA-11POC	1500x800x1450H	1	230/1+T-50	0 ÷ +10	P1CGI+M15-8P3A+S15S1+COP1-15I+LBB-7P
<input type="checkbox"/> LB-11POC	2000x800x1450H	2	230/1+T-50	0 ÷ +10	P2CGI+M20-8P3A+S20S1+COP1-20I+LBB-7P
<input type="checkbox"/> LBB-11POC	2500x800x1450H	2	230/1+T-50	0 ÷ +10	P2CGI+M25-8P3A+S25S1+COP1-25I+LBB-7P-2
<input type="checkbox"/> LC-11POC	2500x800x1450H	3	230/1+T-50	0 ÷ +10	P3CGI+M25-8P3A+S25S1+COP1-25I+LBB-7P
<input type="checkbox"/> LCC-11POC	3000x800x1450H	3	230/1+T-50	0 ÷ +10	P3CGI+M30-8P3A+S30S1+COP1-30I+LBB-7P-2
<input type="checkbox"/> LD-11POC	3000x800x1450H	4	230/1+T-50	0 ÷ +10	P4CGI+M30-8P3A+S30S1+COP1-30I+LBB-7P

Dotazioni basi refrigerate : Nr. 1 coppia guida e nr. 1 griglia per ogni singola anta.

N.B.: Prezzo escluso bacinelle per sovrastrutture

Banchi pizza composti

Tavolo frigorifero con vano per bacinelle da mm. 400x600

Sovrastruttura con vetrina in cristallo e vasca per bacinelle GN1/2

Cassetteria neutra con nr° 3 cassetti e nr° 1 cassettone completo di bacinelle 400x600

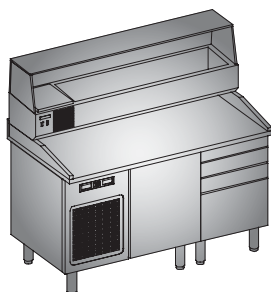

Mod. LA-12CR

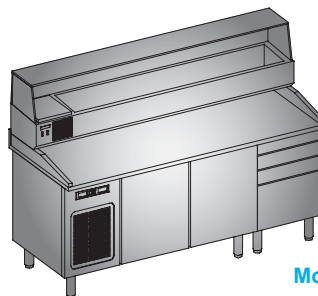

Mod. LB-12CR

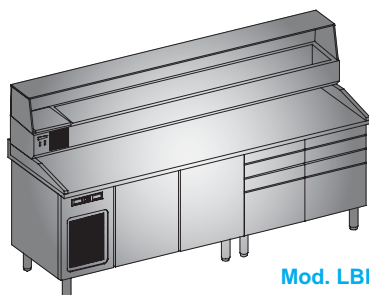

Mod. LBB-12CR

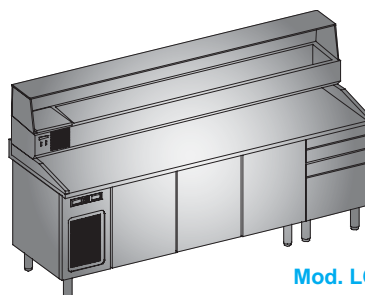

Mod. LC-12CR

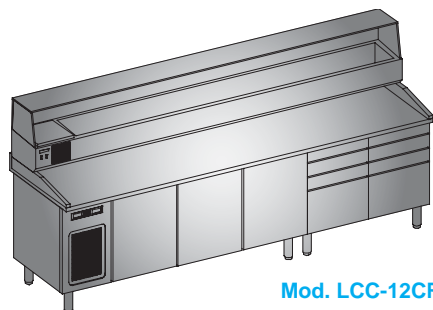

Mod. LCC-12CR

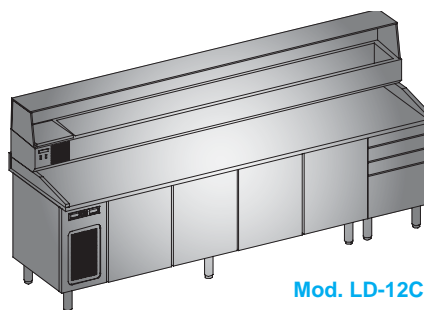

Mod. LD-12CR

Mod.	LxPxH mm	Ante refrigerate	V - Hz	°C	Composizione
<input type="checkbox"/> LA-12CR	1500x800x1450H	1	230/1+T-50	0 ÷ +10	P1CGI + M15-8P3A + S15S2 + V2-15 + LBA-7P
<input type="checkbox"/> LB-12CR	2000x800x1450H	2	230/1+T-50	0 ÷ +10	P2CGI + M20-8P3A + S20S2 + V2-20 + LBA-7P
<input type="checkbox"/> LBB-12CR	2500x800x1450H	2	230/1+T-50	0 ÷ +10	P2CGI + M25-8P3A + S25S2 + V2-25 + LBA-7P-2
<input type="checkbox"/> LC-12CR	2500x800x1450H	3	230/1+T-50	0 ÷ +10	P3CGI + M25-8P3A + S25S2 + V2-25 + LBA-7P
<input type="checkbox"/> LCC-12CR	3000x800x1450H	3	230/1+T-50	0 ÷ +10	P3CGI + M30-8P3A + S30S2 + V2-30 + LBA-7P-2
<input type="checkbox"/> LD-12CR	3000x800x1450H	4	230/1+T-50	0 ÷ +10	P4CGI + M30-8P3A + S30S2 + V2-30 + LBA-7P

Dotazioni basi refrigerate : Nr. 1 coppia guida e nr. 1 griglia per ogni singola ante.

N.B.: Prezzo escluso bacinelle per sovrastrutture

Piani in granito

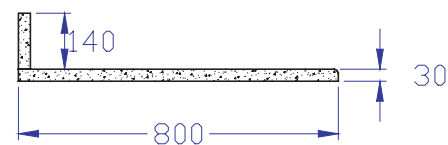
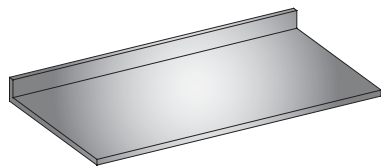

Mod.	LxPxH mm	Descrizione	Kg.	
<input type="checkbox"/> M10-8P1	1.000x800x120H	Con alzatina posteriore H mm. 140	99	0,3
<input type="checkbox"/> M15-8P1	1.500x800x120H	Con alzatina posteriore H mm. 140	116	0,5
<input type="checkbox"/> M20-8P1	2.000x800x120H	Con alzatina posteriore H mm. 140	133	0,6
<input type="checkbox"/> M25-8P1	2.500x800x120H	Con alzatina posteriore H mm. 140	150	0,9
<input type="checkbox"/> M30-8P1	3.000x800x120H	Con alzatina posteriore H mm. 140	170	1,0

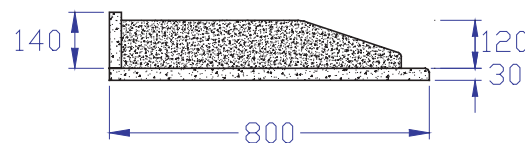
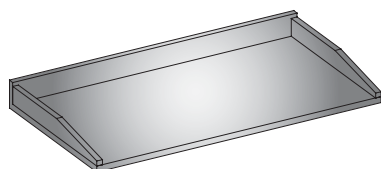

Mod.	LxPxH mm	Descrizione	Kg.	
<input type="checkbox"/> M10-8P3	1.000x800x140H	Con alzatina posteriore H mm. 140, laterali H 120 mm.	109	0,3
<input type="checkbox"/> M15-8P3	1.500x800x140H	Con alzatina posteriore H mm. 140, laterali H 120 mm.	126	0,5
<input type="checkbox"/> M20-8P3	2.000x800x140H	Con alzatina posteriore H mm. 140, laterali H 120 mm.	143	0,6
<input type="checkbox"/> M25-8P3	2.500x800x140H	Con alzatina posteriore H mm. 140, laterali H 120 mm.	160	0,9
<input type="checkbox"/> M30-8P3	3.000x800x140H	Con alzatina posteriore H mm. 140, laterali H 120 mm.	180	1,0

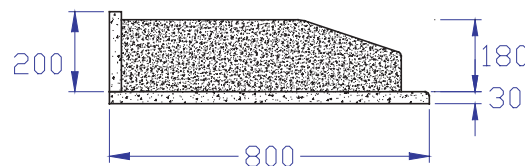
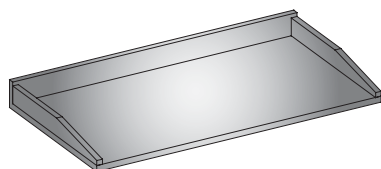

Mod.	LxPxH mm	Descrizione	Kg.	
<input type="checkbox"/> M10-8P3A	1.000x800x200H	Con alzatina posteriore H mm. 200, laterali H 180 mm.	109	0,3
<input type="checkbox"/> M15-8P3A	1.500x800x200H	Con alzatina posteriore H mm. 200, laterali H 180 mm.	126	0,5
<input type="checkbox"/> M20-8P3A	2.000x800x200H	Con alzatina posteriore H mm. 200, laterali H 180 mm.	143	0,6
<input type="checkbox"/> M25-8P3A	2.500x800x200H	Con alzatina posteriore H mm. 200, laterali H 180 mm.	160	0,9
<input type="checkbox"/> M30-8P3A	3.000x800x200H	Con alzatina posteriore H mm. 200, laterali H 180 mm.	180	1,0

Moduli neutri



Mod. LBB-7P

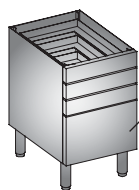

x 3 bacinelle

Mod. LBA-7P

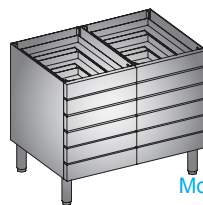

Mod. LBB-7P-2

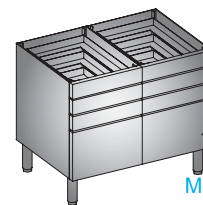

x 3 bacinelle

Mod. LBA-7P-2



Mod. LBB-G-PBS

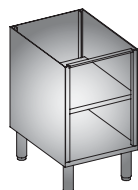

Mod. LB-R



Mod. LANT-P

Mod.	LxPxH mm	Nr° cassetti	Descrizione	Kg.	
<input type="checkbox"/> LBB-7P	500x700x860H	6	Cassettiera completa di nr° 6 bacinelle	55	0,5
<input type="checkbox"/> LBA-7P	500x700x860H	4	Cassettiera completa di nr° 6 bacinelle	45	0,5
<input type="checkbox"/> LBB-7P-2	1000x700x860H	6+6	Cassettiera doppia completa di nr° 12 bacinelle	104	1,0
<input type="checkbox"/> LBA-7P-2	1000x700x860H	4+4	Cassettiera doppia completa di nr° 12 bacinelle	94	1,0
<input type="checkbox"/> LBB-G-PBS	500x700x860H	-	Modulo neutro con nr° 1 telaio portabacinelle per un massimo di nr° 6 bacinelle impilate.	40	0,5
<input type="checkbox"/> LB-R	500x700x860H	-	Modulo neutro con ripiano intermedio	37	0,5
<input type="checkbox"/> LANT-P	500x30x660H	-	Antina a battente per modulo neutro	3	0,01

Accessori a richiesta

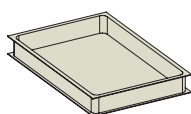

Mod. CSP



Mod. CSP-C

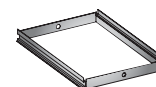

Mod. PBS

Mod.	LxPxH mm	Descrizione	Kg.	
<input type="checkbox"/> CSP	600x400x70H	Bacinella in polietilene atossico	3	0,01
<input type="checkbox"/> CSP-C	400x600	Coperchio in acciaio Inox Aisi304 per bacinella da 400x600	2	0,01
<input type="checkbox"/> PBS	400x600	Telaio porta bacinelle in acciaio Inox Aisi304, scorrevole su guide telescopiche. Utilizzabile anche nelle basi refrigerate con vano 400x600.	10	0,01

Tavoli Frigoriferi - Bacinelle mm. 400x600

Gruppo Incorporato - Temperatura +0°C÷+10°C



Mod.	Porte Nr°	L x P x H	Volt 50 Hz	Watt	Litri	Kg.	
P1CGI	1	1.000x700x860H	230/1+T	180	178	98	0,9

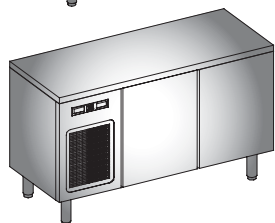

Mod.	Porte Nr°	L x P x H	Volt 50 Hz	Watt	Litri	Kg.	
P2CGI	2	1.500x700x860H	230/1+T	180	325	125	1,3



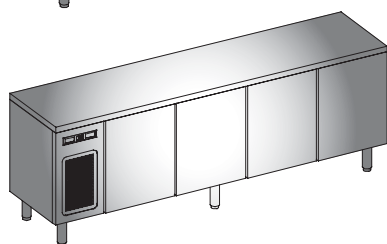

Mod.	Porte Nr°	L x P x H	Volt 50 Hz	Watt	Litri	Kg.	
P3CGI	3	2.000x700x860H	230/1+T	215	504	150	1,7

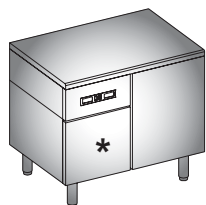

Mod.	Porte Nr°	L x P x H	Volt 50 Hz	Watt	Litri	Kg.	
P4CGI	4	2.500x700x860H	230/1+T	280	683	180	2,1

Gruppo Remoto - Vano neutro con antina a battente (*) - Temperatura +0°C÷+10°C



Mod.	Porte Nr°	L x P x H	Volt 50 Hz	Watt	Litri	Kg.	
P1CA	1	1.000x700x860H	230/1+T	30	178	77	0,9



Mod.	Porte Nr°	L x P x H	Volt 50 Hz	Watt	Litri	Kg.	
P2CA	2	1.500x700x860H	230/1+T	30	325	114	1,3

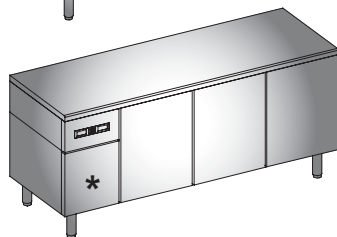

Mod.	Porte Nr°	L x P x H	Volt 50 Hz	Watt	Litri	Kg.	
P3CA	3	2.000x700x860H	230/1+T	30	504	114	1,7

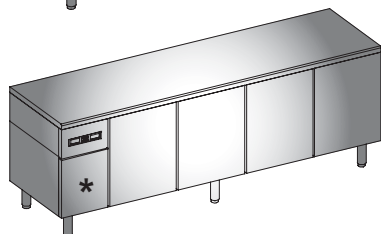

Mod.	Porte Nr°	L x P x H	Volt 50 Hz	Watt	Litri	Kg.	
P4CA	4	2.500x700x860H	230/1+T	30	683	179	2,1

N.B. senza piano di lavoro

Accessori per tavoli frigoriferi

Mod.	LxPxH mm.	Kg.	
------	-----------	-----	---

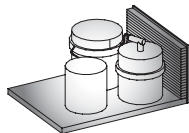

<input type="checkbox"/>	GR212025N	430x310x275H	20	0,1
--------------------------	-----------	--------------	----	-----

Gruppo remoto per base frigorifero - temperatura positiva

• Volt 230/1+T 50Hz • Watt 250 • HP 1/3

N.B. La distanza di collegamento tra il gruppo remoto e la base frigorifero non può essere superiore a mt. 10

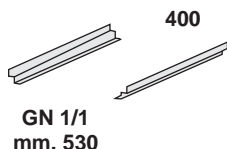

<input type="checkbox"/>	CGTR	per basi 40/60	1,5	0,01
--------------------------	------	----------------	-----	------

coppia guide universali in acciaio Inox AISI 304 per inserimento griglia o bacinella sia GN1/1 sia 400x600.

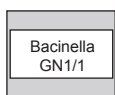

<input type="checkbox"/>	R6040GN	per bacinella GN1/1 mm. 325x530	5	0,01
--------------------------	---------	---------------------------------	---	------

Telaio di riduzione per kit cassette, per permettere l'inserimento di bacinelle GN1/1.

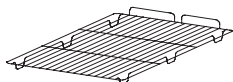

<input type="checkbox"/>	GRI60-40	400x600	2	0,01
--------------------------	----------	---------	---	------

Griglia plastificata

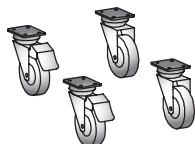

<input type="checkbox"/>	KRU-VER	Ø 100 H 135 mm	4	0,01
--------------------------	---------	----------------	---	------

Applicazione nr. 4 ruote (2 con freno e 2 senza) su supporti

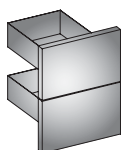

<input type="checkbox"/>	LK-15-7	2 x H 220 mm.	28	0,25
--------------------------	---------	---------------	----	------

Kit cassette con bacinella in acciaio Inox Aisi304

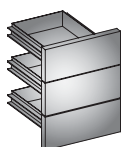

<input type="checkbox"/>	LK-10-7	3 x H 145 mm.	40	0,25
--------------------------	---------	---------------	----	------

Kit cassette con bacinella in acciaio Inox Aisi304

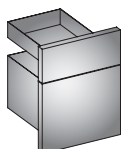

<input type="checkbox"/>	LK-7	1 x H 115 + 1 x H 325 mm.	37	0,25
--------------------------	------	---------------------------	----	------

Kit cassette con bacinella in acciaio Inox Aisi304

N.B. : Il prezzo della cassettera considera la sostituzione della cassettera stessa con l'antina; se le cassettere fossero acquistate indipendentemente dai tavoli i prezzi dovranno essere aumentati di Euro 200,00.



Sovrastruttura refrigerata per pizzeria completa di vetrina in cristallo e di bacinelle

Su piedi

Con piano in marmo con alzatina posteriore

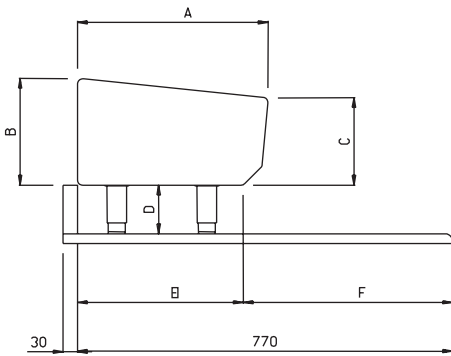

	GN 1/1	GN 1/2
A =	mm 400	mm 340
B =	mm 220	mm 220
C =	mm 180	mm 190
D =	mm 85/125	mm 85/125
E =	mm 345	mm 285
F =	mm 425	mm 485

In appoggio su alzatine laterali

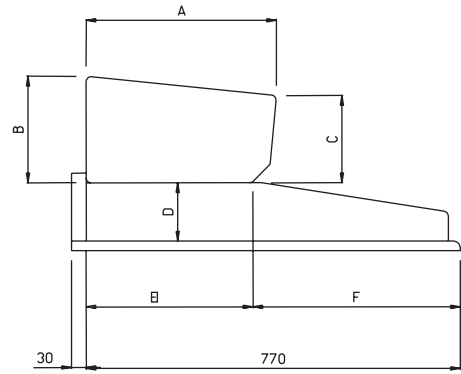

	GN 1/1	GN 1/2
A =	mm 400	mm 340
B =	mm 220	mm 220
C =	mm 180	mm 190
D =	mm 120 / 180	mm 120 / 180
E =	mm 345	mm 285
F =	mm 425	mm 485

Con vetrina

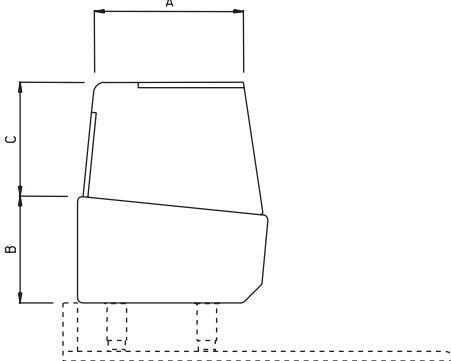

	GN 1/1	GN 1/2
A =	mm 320	mm 260
B =	mm 220	mm 220
C =	mm 230	mm 230

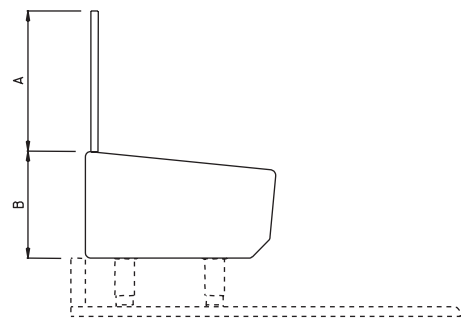

Con coperchio

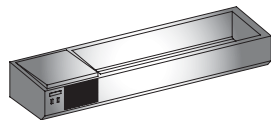

	GN 1/1	GN 1/2
A =	mm 340	mm 280
B =	mm 220	mm 220

Sovrastrutture refrigerate (GN1/1)



Mod.	L x P x H mm	GN 1/1 	V - Hz	W	Hp	Kg.	
S88S1	880x400x220H	1x1/1	230/1/50	150	1/6	21	0,2
S15S1	1500x400x220H	2x1/1	230/1/50	150	1/6	41	0,3
S20S1	2000x400x220H	3x1/1	230/1/50	150	1/6	50	0,4
S25S1	2500x400x220H	4x1/1	230/1/50	150	1/6	60	0,48
S30S1	3000x400x220H	5x1/1	230/1/50	150	1/6	76	0,58

Gruppo incorporato

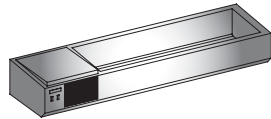



S15S1R	1500x400x220H	2x1/1	230/1/50	-	-	33	0,3
S20S1R	2000x400x220H	3x1/1	230/1/50	-	-	42	0,4
S25S1R	2500x400x220H	4x1/1	230/1/50	-	-	52	0,48
S30S1R	3000x400x220H	5x1/1	230/1/50	-	-	68	0,59

Gruppo remoto

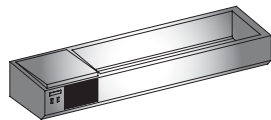
Sovrastrutture refrigerate (GN1/2)



Mod.	L x P x H mm	GN 1/2 	V - Hz	W	Hp	Kg.	
S88S2	880x340x220H	1x1/2+1x1/6+1/9	230/1/50	150	1/6	20	0,2
S15S2	1500x340x220H	3x1/2 + 1x1/4	230/1/50	150	1/6	38	0,3
S20S2	2000x340x220H	5x1/2	230/1/50	150	1/6	48	0,4
S25S2	2500x340x220H	6x1/2 + 1x1/4	230/1/50	150	1/6	58	0,48
S30S2	3000x340x220H	8x1/2	230/1/50	150	1/6	74	0,58

Gruppo incorporato

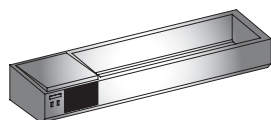

S15S2R	1500x340x220H	3x1/2 + 1x1/4	230/1/50	-	-	30	0,3
S20S2R	2000x340x220H	5x1/2	230/1/50	-	-	40	0,4
S25S2R	2500x340x220H	6x1/2 + 1x1/4	230/1/50	-	-	50	0,48
S30S2R	3000x340x220H	8x1/2	230/1/50	-	-	66	0,59

Gruppo remoto

N.B.: Prezzo escluso bacinelle per sovrastrutture

MONOSCOCCA : è costruita in acciaio inox AISI 304 sia all'interno che all'esterno (ad esaurimento scorte degli involucri in roll-bond); la coibentazione è ottenuta con poliuretano espanso iniettato a corpo unico senza utilizzo di CFC.

VASCA : è realizzata con angoli arrotondati per consentire una perfetta pulizia; in funzione delle due profondità può essere attrezzata o con bacinelle GN1/1 o con bacinelle GN1/2

VANO MOTORE : realizzato in acciaio Inox Aisi304 con frontale grigliato per permettere una corretta areazione dell'impianto frigorifero, viene sempre posizionato alla sinistra della monoscocca.

GRUPPO REFRIGERANTE : completo di compressore, ventilatore e condensatore utilizza fluido refrigerante R134a.

EVAPORATORE : statico, realizzato con tubi di rame a diretto contatto della vasca.

COMANDI : interruttore di accensione e strumento elettronico per il controllo della temperatura.

ACCESSORI A RICHIESTA : vedere pagine seguenti.



Mod.	x L. mm.		Kg.	
<input type="checkbox"/> V1-88	880		23,5	0,17
<input type="checkbox"/> V1-15	1.500		47	0,34
<input type="checkbox"/> V1-20	2.000		50	0,43
<input type="checkbox"/> V1-25	2.500		60	0,6
<input type="checkbox"/> V1-30	3.000		68	0,75

Vetrina in Cristallo stratificato UNI 7172 (mm. 5+5)



Mod.	L x P x H mm		Kg.	
<input type="checkbox"/> COP1-88	880		3,0	0,03
<input type="checkbox"/> COP1-15I	1.500		7,5	0,07
<input type="checkbox"/> COP1-20I	2.000		10	0,09
<input type="checkbox"/> COP1-25I	2.500		14	0,11
<input type="checkbox"/> COP1-30I	3.000		16	0,13

Coperchio in acciaio Inox Aisi304 per sovrastruttura

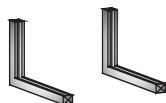

Mod.	x L mm.	N°		Kg.	
<input type="checkbox"/> KZ1-A	1.500/2.000	2		2	0,02
<input type="checkbox"/> KZ1-B	2.500/3.000	3		3	0,02

Zanche di sostegno a parete per sovrastruttura



Mod.	x L mm.	H mm.	N°		Kg.	
<input type="checkbox"/> KP	1.500/2.000	85 / 125	4		2	0,02

Kit piedi



Mod.		Kg.	
<input type="checkbox"/> TRA1-1		0,5	0,01

Separatore in ABS per bacinelle



Mod.	L x P x H mm	V - Hz	W	Hp	Kg.	
<input type="checkbox"/> GE-SVRN	420x300x265h	230/1/50	125	1/6	15	0,1

Gruppo remoto - Gas R134a

N.B. la distanza di collegamento tra il gruppo remotato e la sovrastruttura non può essere superiore a metri 10.



Mod.	x L. mm.		Kg.	
<input type="checkbox"/> V2-88	880		23,5	0,17
<input type="checkbox"/> V2-15	1.500		47	0,34
<input type="checkbox"/> V2-20	2.000		50	0,43
<input type="checkbox"/> V2-25	2.500		60	0,6
<input type="checkbox"/> V2-30	3.000		68	0,75

Vetrina in Cristallo stratificato UNI 7172 (mm. 5+5)

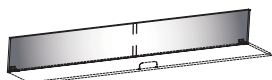

Mod.	L x P x H mm		Kg.	
<input type="checkbox"/> COP2-88	880		3,0	0,03
<input type="checkbox"/> COP2-15I	1.500		7,5	0,07
<input type="checkbox"/> COP2-20I	2.000		10	0,09
<input type="checkbox"/> COP2-25I	2.500		14	0,11
<input type="checkbox"/> COP2-30I	3.000		16	0,13

Coperchio in acciaio Inox Aisi304 per sovrastruttura



Mod.	x L mm.	N°		Kg.	
<input type="checkbox"/> KZ2-A	1.500/2.000	2		2	0,02
<input type="checkbox"/> KZ2-B	2.500/3.000	3		3	0,02

Zanche di sostegno a parete per sovrastruttura



Mod.	x L mm.	H mm.	N°		Kg.	
<input type="checkbox"/> KP	1.500/2.000	85 / 125	4		2	0,02

Kit piedi



Mod.		Kg.	
<input type="checkbox"/> TRA1-2		0,5	0,01

Separatore in ABS per bacinelle



Mod.	L x P x H mm	V - Hz	W	Hp	Kg.	
<input type="checkbox"/> GE-SVRN	420x300x265h	230/1/50	125	1/6	15	0,1

Gruppo remoto - Gas R134a

N.B. la distanza di collegamento tra il gruppo remotato e la sovrastruttura non può essere superiore a metri 10.

Bacinelle - Coperchi

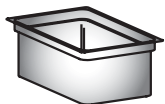

Bacinelle in acciaio inox



Coperchi in acciaio inox

Mod.	L x P x H
D2	GN 1/1 H 150
D5	GN 2/3 H 150
D8	GN 1/2 H 150
D11	GN 1/3 H 150
D20	GN 1/4 H 150
D23	GN 1/6 H 150
D22	GN 1/9 H 100

Mod.	L x P x H
D3	GN 1/1
D6	GN 2/3
D9	GN 1/2
D12	GN 1/3
D21	GN 1/4
D24	GN 1/6
D25	GN 1/9

Composizioni bacinelle per sovrastrutture (mm. 880)

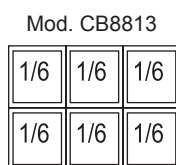
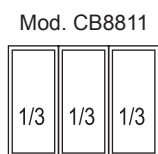

Per GN 1/1

Mod.
CB8811
CB8812
CB8813

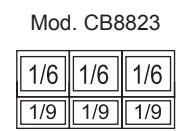
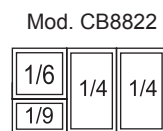
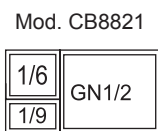

Per GN 1/2

Mod.
CB8821
CB8822
CB8823

N.B.: Le bacinelle GN 1/9 incluse nelle composizioni hanno un'altezza pari a mm 100 anzichè 150.
N.B.: Tutte le composizioni sono prive di coperchi

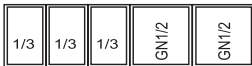

mm 1500

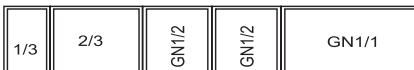
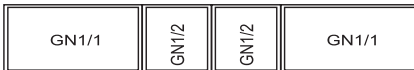
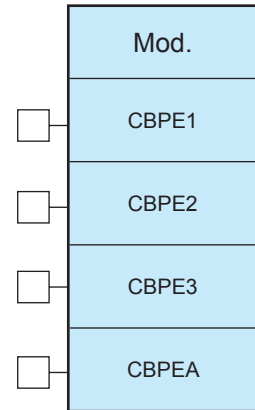

mm 2000

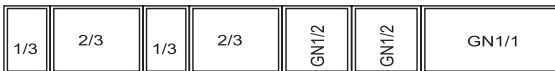
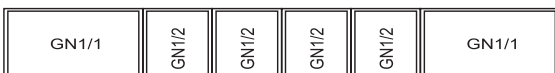
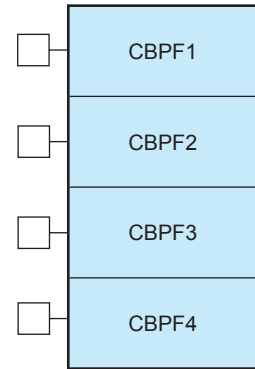

mm 2500

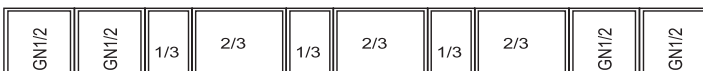
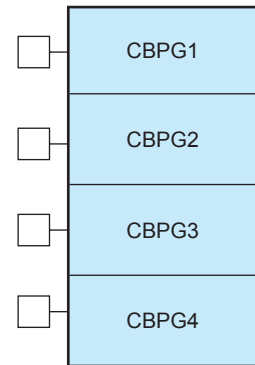

mm 3000

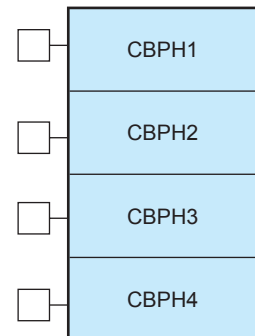

N.B. : Tutte le composizioni prevedono babinelle H mm. 150 e sono prive di coperchi

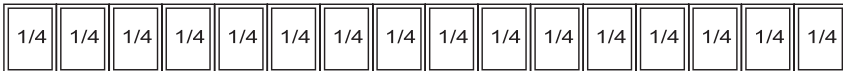
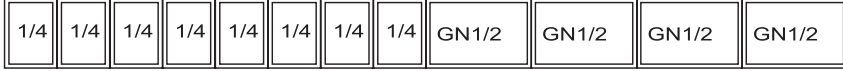
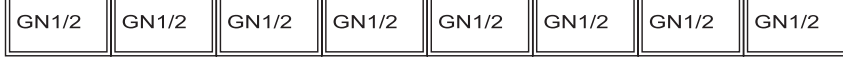
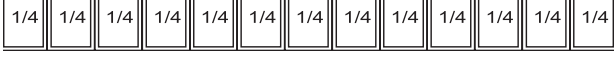
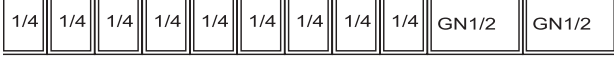
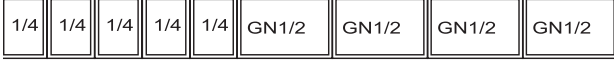
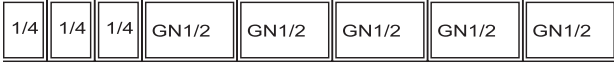
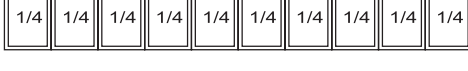
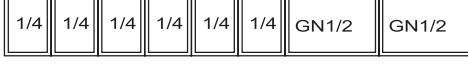

mm 1500

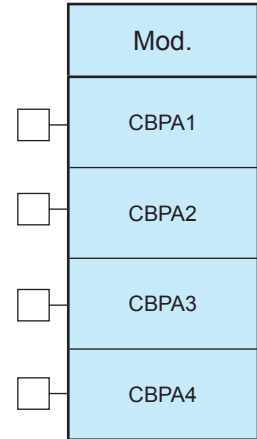

mm 2000

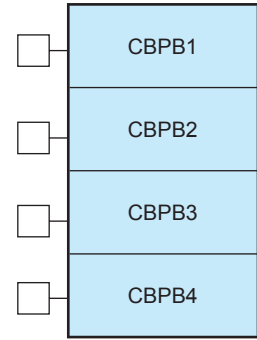

mm 2500

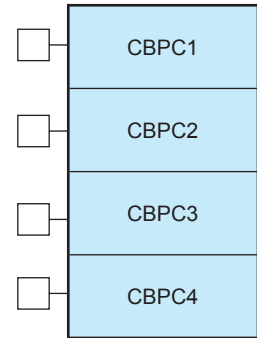

mm 3000

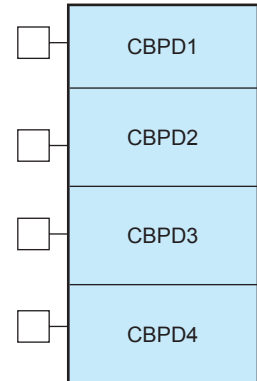

N.B. : Tutte le composizioni prevedono babinelle H mm. 150 e sono prive di coperchi